

Wide Input sensorless CC/CV 2A Buck Converter

General Description

AT2003 is a wide input voltage, high efficiency step-down DC/DC converter that operates in either CV (Constant Output Voltage) mode or CC (Constant Output Current) mode. AT2003 provides up to 3A output current at 120kHz switching frequency, and the CC level can be adjusted by changing external sensing resistor.

The AT2003 provides full protection functions, thermal shutdown is to prevent over temperature operating from damage; cycle by cycle current limit is against over current operating of the switch; and over voltage protection (OVP) that can avoid high Vout voltage to damage circuit and capacitor.

The device is available in PSOP8-8L package and require very few external devices for operation.

Features

- ❑ Wide Input Voltage with 9V ~ 40V Operation
- ❑ Up to 3A Output Current
- ❑ Fixed Frequency 120 kHz with Easy EMI Control
- ❑ Constant voltage and constant voltage control
- ❑ Precision Feedback Voltage 1.2V+1%
- ❑ Precision CC Limit with +5% Accuracy
- ❑ Integrated 140mohm High Side NMOS
- ❑ Internal MOS 4.5A Current Peak Protected in Cycle by Cycle Current Limit
- ❑ PSOP8-8 Package

Applications

- ❑ Car Charger/Adaptor
- ❑ General-Purposed DC/DC Converters with Constant Current Limit
- ❑ Rechargeable Portable Devices

Pin Configuration

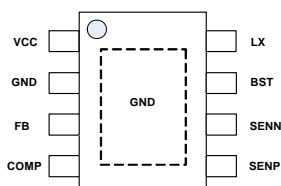

Ordering and Marking Information

Order Number	Package	Top Marking
AT2003ZSP8	PSOP-8L	AT2003Z

Note: Aplustek products are compatible with the current IPC/JEDEC J-STD-020 requirement. They are halogen-free, RoHS compliant and 100% matte tin (Sn) plating that are suitable for use in SnPb or Pb-free soldering processes.

Typical Application Circuit

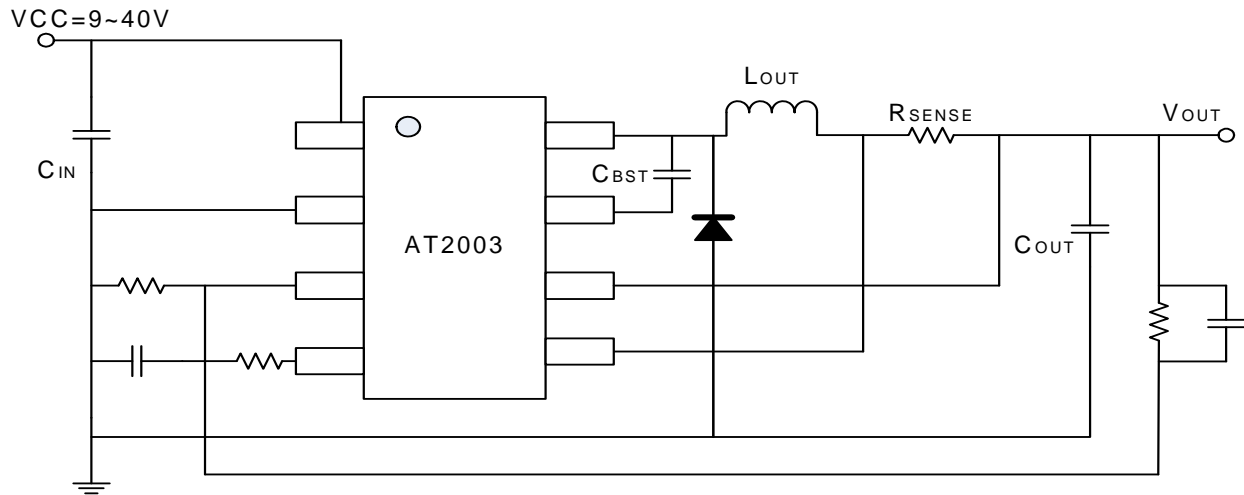

Function Blocks

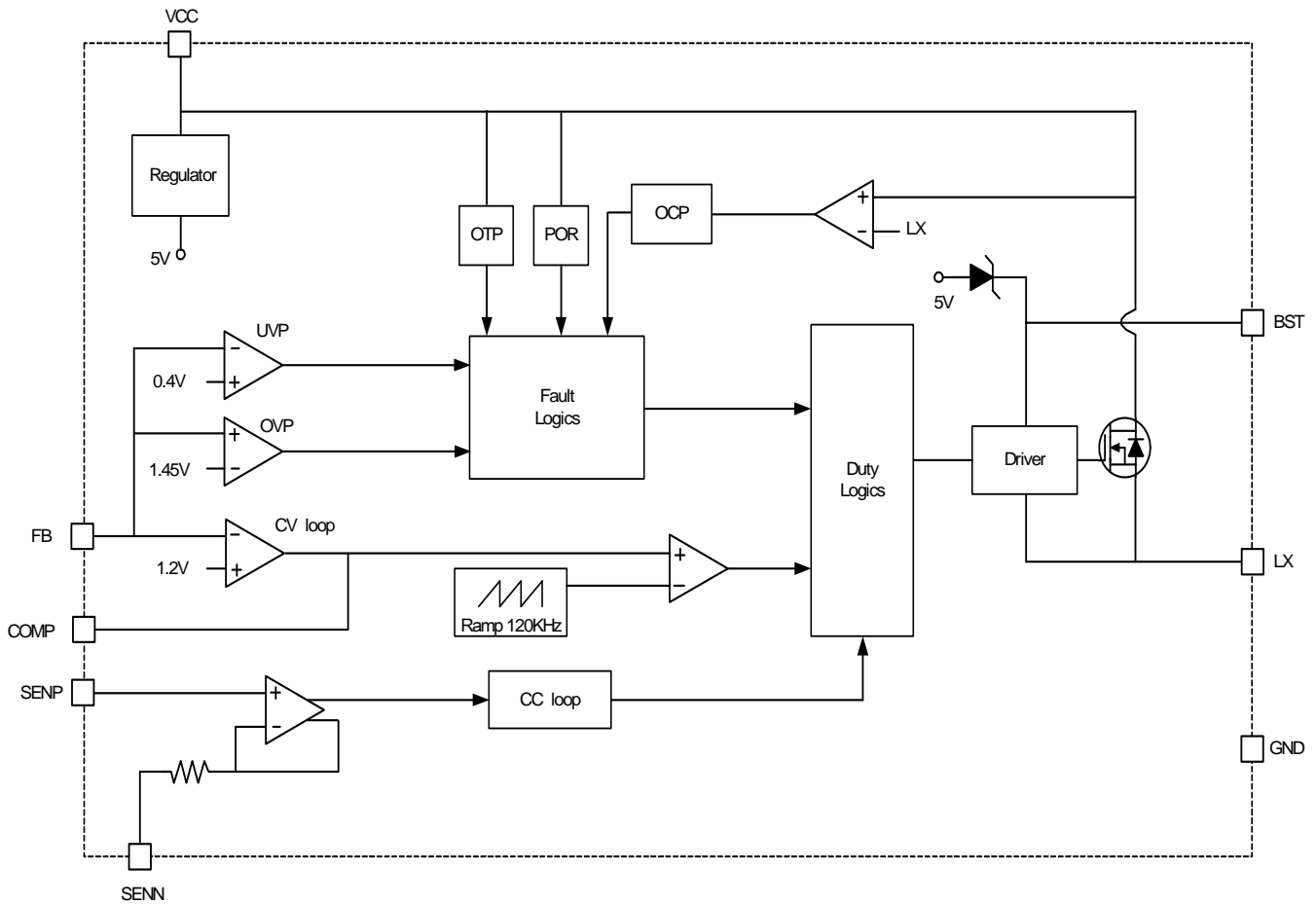

Function Pin Description

No.	Pin Name	Pin Function
1	VCC	Power Supply Input. Bypass this pin with a 0.1uF ceramic capacitor to GND, placed as close to the IC as possible.
2	GND	Ground.
3	FB	Feedback Input. The voltage at this pin is regulated to 1.2V. Connect to resistor divider between output and GND to set the output voltage.
4	COMP	Error Amplifier output Pin. The pin is used to compensate the converter.
5	SENP	Current sense positive input pin.
6	SENN	Current sense negative input pin.
7	BST	Bootstrap Bias Pin. It provides power to the internal high-side MOSFET gate driver. Connect a 0.1uF capacitor from BST to LX pin.
8	LX	Power Switching Output to external Inductor.

Absolute Maximum Ratings

(Note1)

Supply Input Voltage, V_{CC}	-0.3V to +44V
BST to LX	-0.3V to +7V
LX to GND DC	-0.3V to +44V
FB,COMP to GND DC	-0.3V to +7V
Storage Temperature Range	-65°C to +150°C
Junction Temperature	-40°C to +150°C
Lead Temperature Range(Soldering 10sec)	260°C
ESD Rating (Note2)	
HBM(Human Body Mode)	2KV
MM(Mechine Mode)	200V

Thermal Characteristics

Package Thermal Resistance (Note3)

PSOP-8L θ_{JA}	50°C/W
PSOP-8L θ_{JC}	5°C/W

Power Dissipation, PD @ TA= 25°C

PSOP-8L	2.0W
---------	------

Electrical Characteristics

($V_{CC} = 12V$, $T_A = +25^\circ C$ unless otherwise specified.)

Parameter	Symbol	Test Conditions	Min	Typ	Max	Units
Supply Input Section						
VCC operation range	$V_{CC,R}$		9	--	40	V
VCC UVLO threshold	$V_{CC,R}$	VCC Rising	--	8.2	--	V
	$V_{CC,F}$	VCC Falling	--	6.3	--	V
VCC operation current	I_{CC}	VCC=9V to 40V, COMP short to FB	--	1	1.5	mA
Oscillation Section						
PWM Frequency	F_{SW}		--	120	--	kHz
			-15%	--	+15	%
Max Duty	D_{MAX}		--	90	--	%
PWM loop Section						
Feedback reference voltage	V_{REF}		--	1.2	--	V
Feedback reference accuracy			-1%	--	+1%	%
COMP source current		FB<1.2V	--	85	--	uA
COMP sink current		FB>1.2V	--	85	--	uA
COMP High voltae		FB<1.2V	--	4.3	--	V
COMP Low voltae		FB>1.2V	--	0.8	--	V
Fault protection Section						
FB under voltage level	V_{UVP}		--	0.4	--	V
FB over voltage level	V_{OVP}		--	1.45	--	V
FB short Impedance level	V_{SHORT}		--	0.2	--	V
Over Tempperature level	T_{OTP}		--	150	--	°C
	T_{HYS}		--	40	--	°C

Parameter	Symbol	Test Conditions	Min	Typ	Max	Units
Fault protection Section						
CC Control accuracy			-5	--	+5	%
Internal Soft Start time	T_{SS}		--	4.5	--	mS
Fault recycle waiting time	$T_{recycle}$		--	0.5	--	S
High side MOS Section						
High side MOS ON resistance	R_{DSON}		--	0.14	--	ohm
High Side MOS peak current Limit			--	4.5	--	A

Note 1. Exceeding these limits may impair the life of the device. Exposure to absolute maximum rating conditions for long periods may affect device reliability.

Note 2. θ_{JA} is measured with the component mounted on a high effective thermal conductivity test board in free air. The exposed pad of the package is soldered directly on the PCB.

Typical Operation Characteristics

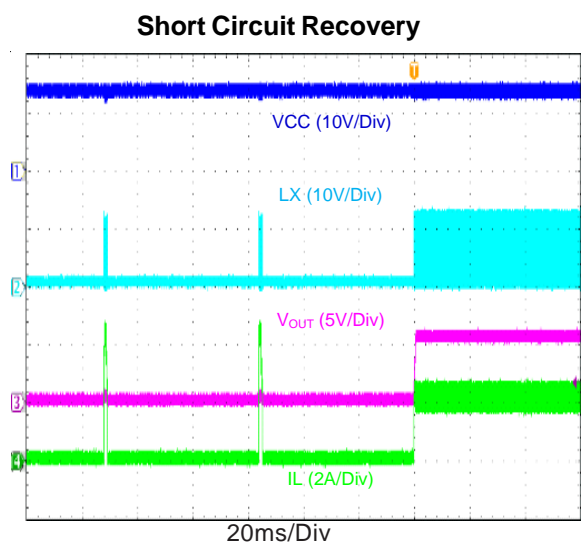
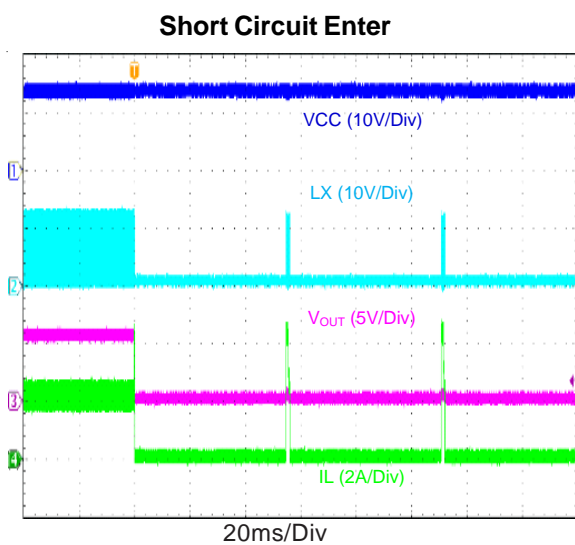
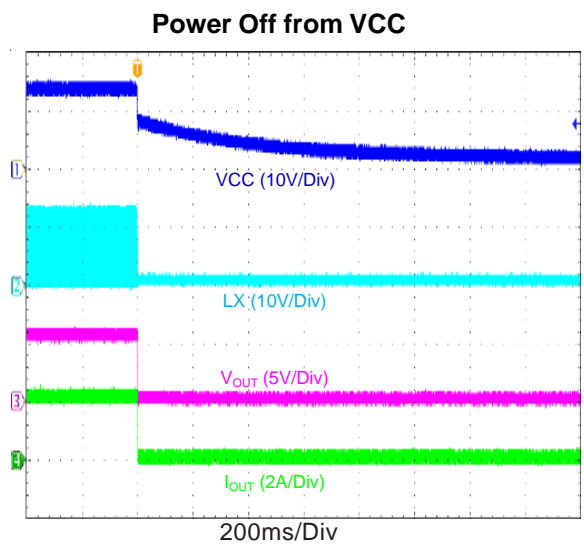
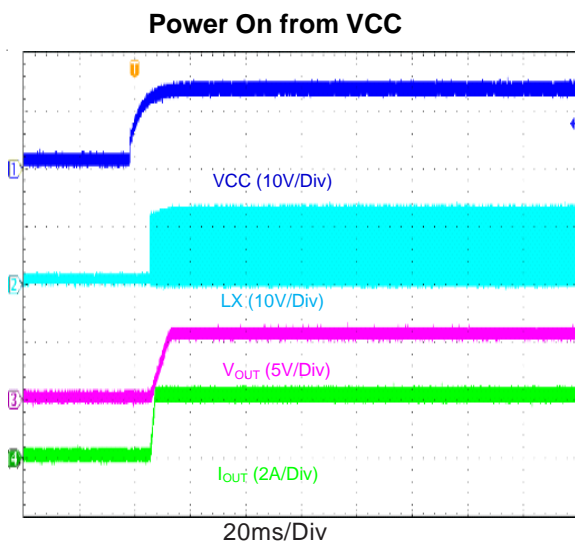
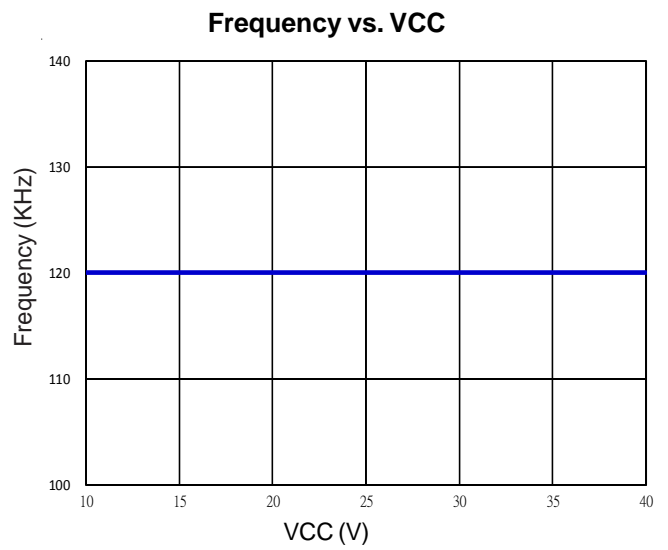
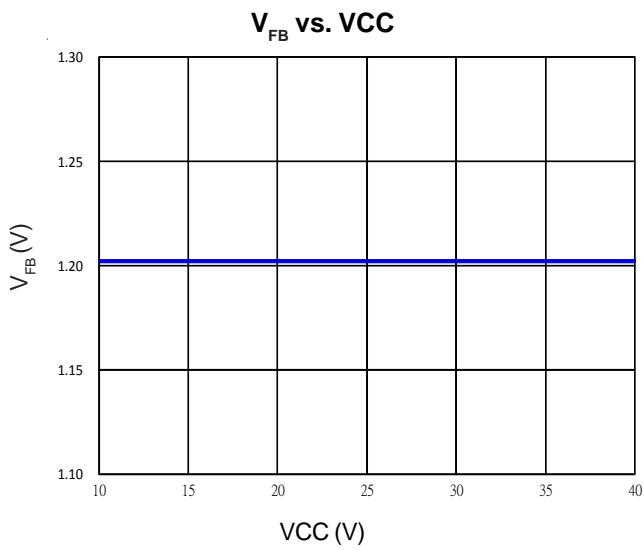

Package Information

PSOP-8L

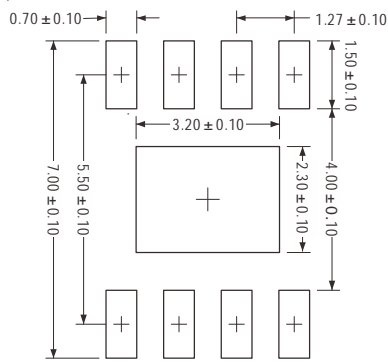

Recommended Solder Pad Layout

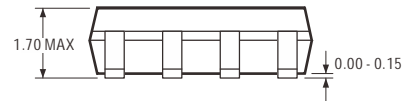
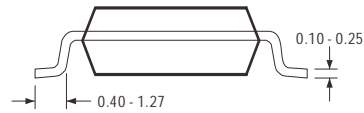
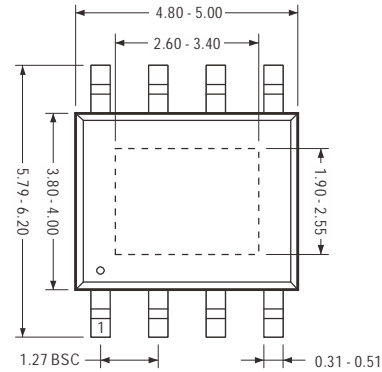

Note

1. Package Outline Unit Description:

BSC: Basic. Represents theoretical exact dimension .

MAX: Maximum dimension specified.

MIN: Minimum dimension specified.

REF: Represents dimension for reference use only. The value is not the device specification.

TYP: Represents as a typical value. The value is not the device specification.

2. All linear dimensions are in Millimeters.