



Interleaving two Phase CRM/CCM Operation Power Factor Correction Controller

General Description

AT6201Z is an advanced active power factor corrected controller that integrates two 180 out of phase PWM to drive PFC boost stages base on ATK patented Pseudo Digital Loop(PDL) control method.

In PDL control ,AT6201Z classically operates in Critical conduction Mode(CRM) when the inductor current below a programmable value. When the current is exceed this preset level ,the AT6201Z natural change to Continuous conduction Mode(CCM). The loop stability and response is controlled by PDL. AT6201Z features a robust suite of protection features to properly handle an array of power supply operating and fault condition.

The devices is available in TSSOP-20L package and require few external devices for operation.

Applications

- High Efficiency Server and Desktop Power Supplies
- Telecom Rectifiers
- High Power Adaptor
- Off Line Appliances Requiring Power Factor Correction

Pin Configuration

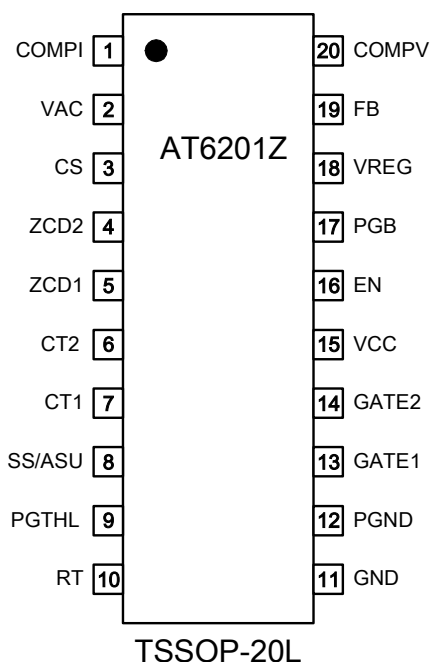

Features

- Pseudo Digital Control Loop without Analog multiplier
- Average Current Mode Interleaving PWM Control with Inherent Current Matching
- Quick Transient Response
- Intelligent AC Power Sag Protection
- Multi-Mode CRM/CCM operation
- Programmable Soft Start
- Programmable CCM Operation Frequency 18kHz~130kHz
- Sourcing 1A/Sinking 1A High Drive Capability Driver
- Brown In/Out protection
- Bias-Supply UVLO ,Over-Voltage Protection ,Open-Loop Detection ,
- TSSOP-20L Package

Ordering and Marking Information

Order Number	Package	Top Marking
AT6201ZSPF	TSSOP-20L	AT6201Z

Note: Aplustek products are compatible with the current IPC/JEDEC J-STD-020 requirement. They are halogen-free, RoHS compliant and 100% matte tin (Sn) plating that are suitable for use in SnPb or Pb-free soldering processes.

Typical Application Circuit

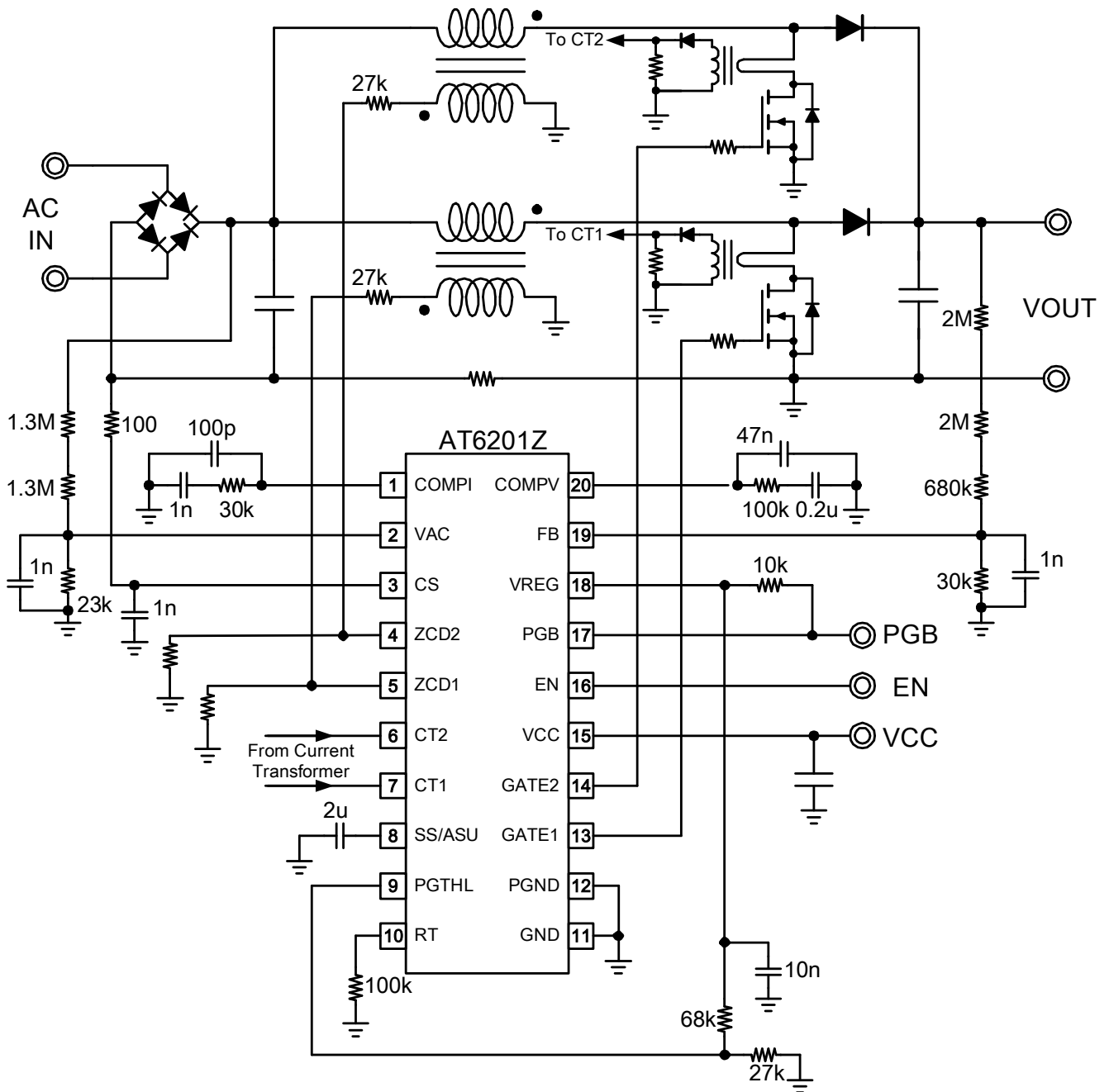

Function Blocks

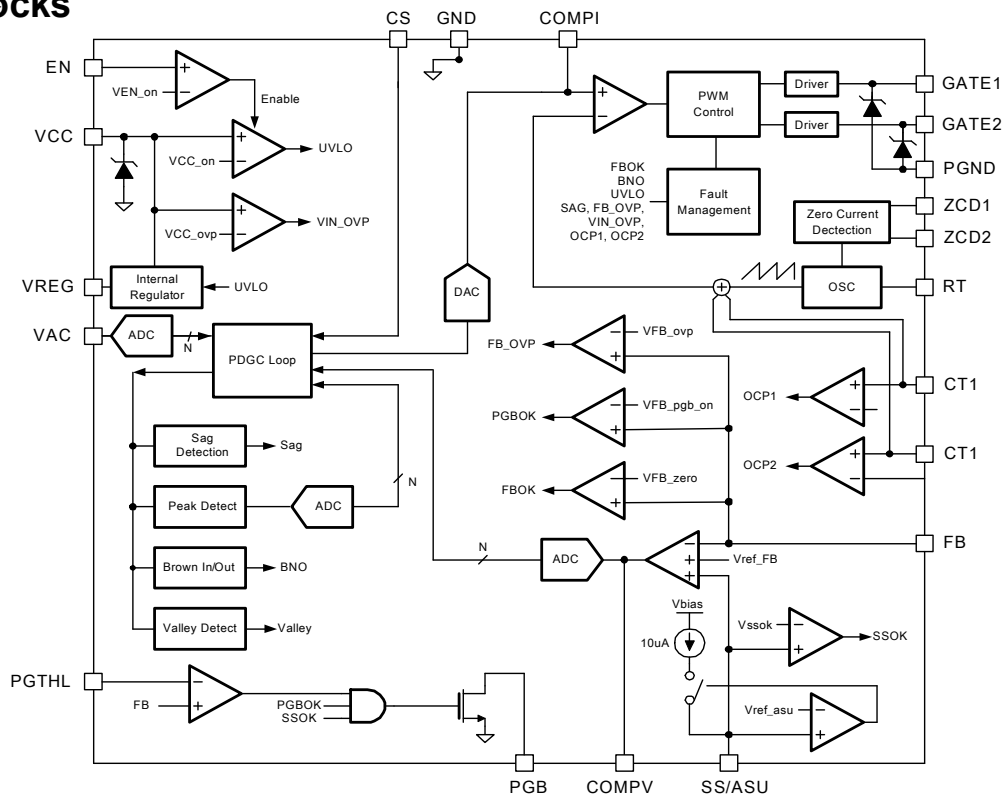

Function Pin Description

No.	Pin Name	Pin Function
1	COMPI	Current error amplifier output.
2	VAC	AC line sense input pin.
3	CS	PFC current sense.
4	ZCD2	Channel2 Zero current detect input Pin. Pull low would operate in CCM, Pull high would Shutdown Channel2.
5	ZCD1	Channel1 Zero current detect input Pin. Pull low would operate in CCM, Pull high would Shutdown Channel1 and 2..
6	CT2	Channel2 current transformer detect input Pin.
7	CT1	Channel1 current transformer detect input Pin.
8	SS/ASU	Soft Start time setting input pin.
9	PGTHL	An I/O pin. Setting for Power Good threshold to determine PGB to be pull high level.
10	RT	CCM switching Frequency input pin.
11	GND	Ground.
12	PGND	Gate Driver1/2 GND.
13	Gate1	Channel1 Gate Driver output Pin.
14	Gate2	Channel2 Gate Driver output Pin.
15	VCC	Positive Supply for AT6201Z.
16	EN	IC Enable pin.
17	PGB	Power Good comparator output pin.
18	VREG	Reference Voltage output pin.
19	FB	Voltage error amplifier input.
20	COMPV	Voltage error amplifier output.



Absolute Maximum Ratings

(Note1)

Supply Input Voltage, V_{cc}	-----	-0.3V to +27V
PGB,EN to GND DC	-----	-0.3V to +27V
CS to GND DC	-----	-6V to +0.3V
Gate1/2 to GND DC	-----	-0.3V to 21V
COMPI,VAC,ZCD1/2,SS/ASU,PGTHL,RT,VREG,FB,COMPV,CT1/2 to GNDDC	-----	-0.3V to +7V
Storage Temperature Range	-----	-65°C to +150°C
Junction Temperature	-----	-40°C to +150°C
Lead Temperature Range(Soldering 10sec)	-----	260°C
ESD Rating (Note2)		
HBM(Human Body Mode)	-----	-2KV
MM(Mechine Mode)	-----	-200V

Thermal Characteristics

Package Thermal Resistance (Note3)

TSSOP-20L θ_{JA}	-----	76°C/W
-------------------------	-------	--------

Power Dissipation, PD @ TA = 25°C

TSSOP-20L	-----	1.3W
-----------	-------	------

Electrical Characteristics

($V_{cc} = 12V, T_A = +25°C$ unless otherwise specified.)

Parameter	Symbol	Test Conditions	Min	Typ	Max	Units
VCC Supply Input Section						
VCC operation range			10	--	21	V
VCC UVLO threshold	$V_{CC,on}$	VCC Rising	9.6	10	10.4	V
	$V_{CC,off}$	VCC Falling	7.6	8	8.3	V
Over Voltage Protection Voltage	$V_{CC,ovp}$		22.5	24	25.5	V
Inter Zener Clamp	$V_{CC,clamp}$	$I_{VCC}=10mA, CL=0$	25.5	27	28.5	V
Startup current	$I_{CC,start}$		--	50	120	uA
Normal operation current	$I_{CC,op}$	$CL=2nF$	--	2.5	3.5	mA
VAC Section						
Brown In Threshold	VAC_brown_in		0.988	1	1.012	V
Brown In Debounce Time	Tdeb_brown_in		175	200	225	uS
Brown Out Threshold	VAC_brown_out		0.925	0.94	0.955	V
Brown Out Debounce Time	Tdeb_brown_out		400	440	480	mS
Pull low Impedance	ZVAC		470	500	600	kohm
High Line Threshold	VAC_hline	Sweep VAC from low to high	2.2	2.35	2.5	V
Low Line Threshold	VAC_lline	Sweep VAC from high to low	1.95	2.1	2.25	V
Low Threshold for Valley Detect	VAC_valley_l		0.3	0.35	0.4	V
High Threshold for Valley Detect	VAC_valley_h		0.66	0.72	0.8	V
SAG Debounce Time	Tdeb_sag		4.5	5	5.5	mS
Product of VAC Peak and Internal VAC Peak			5.05	5.4	5.85	V*V



Parameter	Symbol	Test Conditions	Min	Typ	Max	Units
CS Section						
Delay to Output			150	250	350	nS
Threshold to off PWM at low Line	VCS_max_lline		-1.7	-1.56	-1.42	V
Threshold to off PWM at lhigh Line	VCS_max_hline		-1.03	-0.94	-0.84	V
Input Impedance	ZCS		20	--	--	kohm
Max Fain of CS over Internal VAC			0.19	0.2	0.21	V/V
ZCD 1/2 Section						
Negative Clamp Voltage	VZCD_clamp_l		-0.4	-0.6	-0.8	V
Positive Clamp Voltage	VZCD_clamp_h		5.8	6.1	6.4	V
Falling Threshold for Zero Current Detection	VZCD_zero_fall	Sweep ZCD from high to low	0.35	0.4	0.45	V
Rising Threshold for Zero Current Detection	VZCD_zero_rise	Sweep ZCD from low to high	0.45	0.5	0.55	V
Threshold to Keep low to off CRM mode	VZCD_crm_off		0.35	0.4	0.45	V
Threshold to Keep high to off PWM mode	VZCD_pwm_off		0.45	0.5	0.55	V
CT 1/2 Section						
Threshold to off PWM at Low Line	VCT_max_lline			3.5		V
Threshold to off PWM at High Line	VCT_max_hline			2.1		V
Leading Edge Blanking Time	t_leb			300		nS
SS/ASU Section						
Voltage lower than VCC in Power On for ASU mode			--	2	2.5	V
Charging Current in SS mode	ISS		9.5	10	12.5	uA
Soft Start Time in ASU mode	t_ss		150	175	200	mS
PGTHL Section						
FB voltage to pull PGB High	VFB_pgb_off	PGTHL=2V	1.98	2	2.02	V
PGB Section						
Output Voltage Low	Vpgb_ol	Io=10mA Sinking	--	0.15	0.5	V
RT Section						
Nominal Frequency	fosc	connect 100kohm to GND	62.5	65	67.5	kHz
Resister Range			40	--	400	kohm
Frequency Variation vs.VCC			--	--	2	%
Frequency Variation vs. Temperature			--	--	2	%



Parameter	Symbol	Test Conditions	Min	Typ	Max	Units
COMPI Section						
Transconductance	gm_compi		60	72	88	uohm
Input Offset Voltage	vos_compi		-1	-	1	mV
Max Sink Current	Isink_max_compi		-44	-36	-30	uA
Max Source Current	Isource_max_compi		30	36	44	uA
Clamp High Voltage	VCOMPI_clamp_h		4.1	4.3	4.5	V
Clamp Low Voltage	VCOMPI_clamp_l		0.39	0.52	0.65	V
Threshold for Zero Duty	VCOMPI_zero		0.7	0.77	0.94	V
COMPV Section						
Transconductance	gm_compv		60	72	88	uohm
Input difference with GM Boost	Vdiff_gn_boost		-75	-100	-150	mV
Transconductance with GM Boost	gm_compvl_boost		135	163	200	uohm
Max Sink Current	Isink_max_compv		-44	-36	-30	uA
Max Source Current	Isource_max_compv		30	36	44	uA
Clamp High Voltage	VCOMPV_clamp_h		4.15	4.3	4.45	V
Clamp Low Voltage	VCOMPV_clamp_l		0.6	0.72	0.85	V
Threshold for Zero Duty	VCOMPV_bs		0.68	0.8	0.93	V
Threshold for Single Mode	VCMOP_single	Sweep COMPV from High to Low		1.585		V
Hysteresis of Single Mode Threshold				117		mV
FB Section						
Reference Voltage at High Feedback Mode	Vref_FB_hfb		2.5	2.515	2.53	V
Debounce of Low Feedback Mode	Tdeb_lfb		0.8	1	1.2	S
Threshold for FB OVP	VFB_ovp	Sweep FB from Low to High	2.65	2.75	2.85	V
Hysteresis of FB OVP Threshold			150	200	250	mV
Threshold for PGB Pull Low	VFB_pgb_on		2.1	2.2	2.3	V
Threshold to off PWM	VFB_pwm_off		0.35	0.4	0.45	V
VREG Section						
Output Voltage	Vreg		5.96	6	6.04	V
Line Regulation		0mA<k<3mA	-	1	5	mV
Load Regulation			-	4	20	mV
Max Output Current			10	15	-	mA
EN Section						
Threshold to Enable Controller	VEN_on			2.25		V
Hysteresis of EN Threshold				100		mV



Parameter	Symbol	Test Conditions	Min	Typ	Max	Units
Gate 1/2 Section						
Maximum Duty Cycle	Dmax		95	98	–	%
Output Voltage Low	Vol	VCC=12V, I _o =20mA Sinking	–	0.07	0.15	V
Output Voltage High	Voh	VCC=12V, I _o =20mA Sinking	10	11.1	–	V
Rising Time	t _r	CL=2nF, VGATE from 2V to 6V	–	30	85	nS
Falling Time	t _f	CL=2nF, VGATE from 6V to 2V	–	10	55	nS
Gate Clamping Voltage	V _{gate_clamp}	VCC=21V	12	15	18	V
Output Phase Shift				180		Degree
TSD Section						
Internal Thermal Protection	TSD_int		135	150	165	Degree
Hysteresis of Thermal Protection	TSD_int_hys		15	20	25	Degree

Note 1. Exceeding these limits may impair the life of the device. Exposure to absolute maximum rating conditions for long periods may affect device reliability.

Note 2. θ_{JA} is measured with the component mounted on a high effective thermal conductivity test board in free air. The exposed pad of the package is soldered directly on the PCB.



Typical Operation Characteristics

Package Information

TSSOP-20L

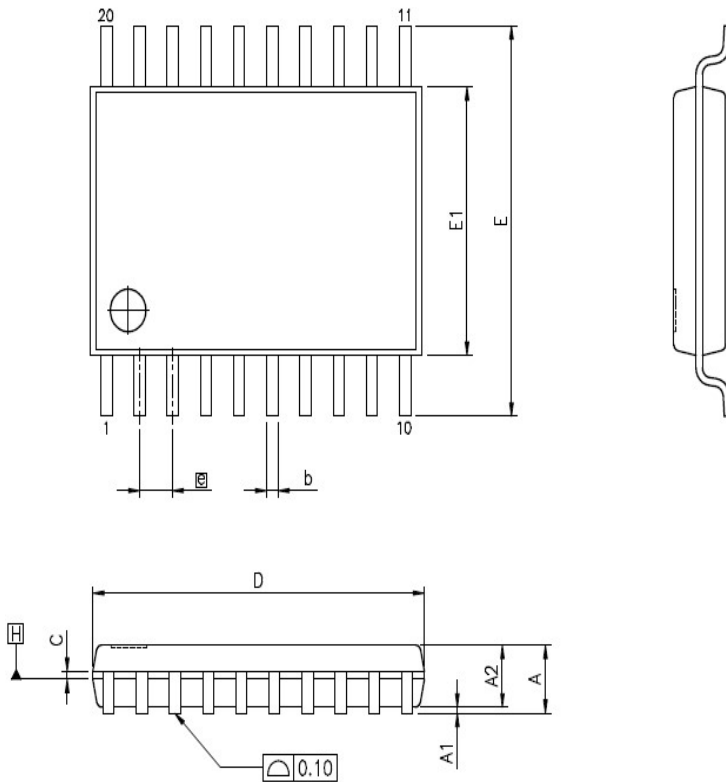

VARIATIONS (ALL DIMENSIONS SHOWN IN MM)

SYMBOLS	MIN.	NOM.	MAX.
A	—	—	1.20
A1	0.05	—	0.15
A2	0.80	0.90	1.05
b	0.19	—	0.30
C	0.09	—	0.20
D	6.40	6.50	6.60
E1	4.30	4.40	4.50
E	6.40 BSC		
e	0.65 BSC		
L1	1.00 REF		
L	0.50	0.60	0.75
S	0.20	—	—
θ	0°	—	8°

Note

1. Package Outline Unit Description:

BSC: Basic. Represents theoretical exact dimension .

MAX: Maximum dimension specified.

MIN: Minimum dimension specified.

REF: Represents dimension for reference use only. The value is not the device specification.

TYP: Represents as a typical value. The value is not the device specification.

2. All linear dimensions are in Millimeters.

